

‘Naked DSL’ – first experiences in Europe

ETP Plenary meeting

Wholesale – A Driver for Telco Business

Tuesday 6 December 2005

**Veronica Bocarova
Cullen International**

veronica.bocarova@cullen-international.com

Outline

- **Concept introduction**
- **‘Naked / unbundled DSL’ definition**
- **‘Naked DSL’ over shared access**
- **‘Naked DSL’ over bitstream access**
- **Conclusions**

PSTN and DSL services by local loop operator

Scenario 1 local loop operator provides PSTN voice and DSL broadband services using entire spectrum of the copper loop

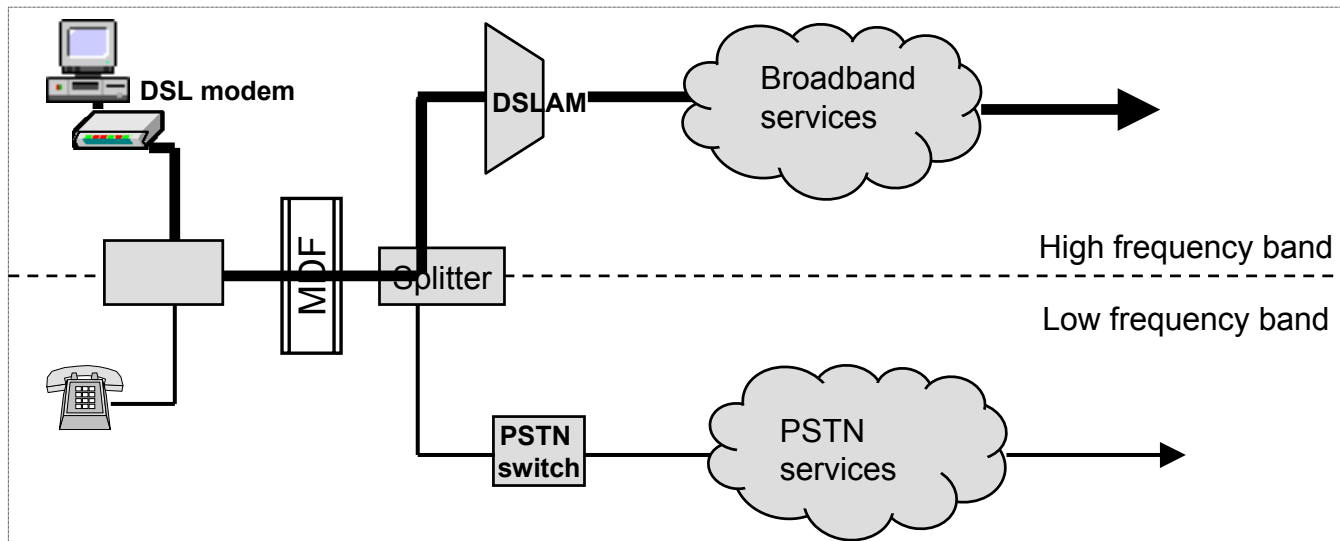

Full unbundled access

Scenario 2 alternative operator provides PSTN voice and DSL broadband services using entire spectrum of the copper loop

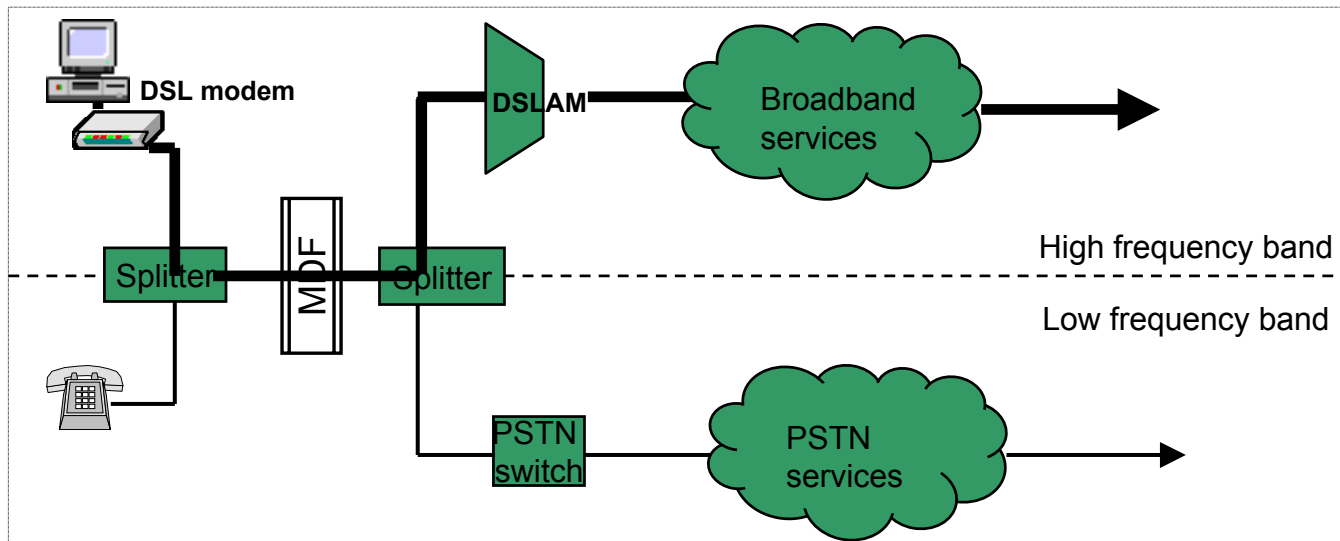

Shared access

Scenario 3 alternative operator provides DSL broadband services in high frequency band

local loop operator (or WLR provider) provides PSTN services in low frequency band

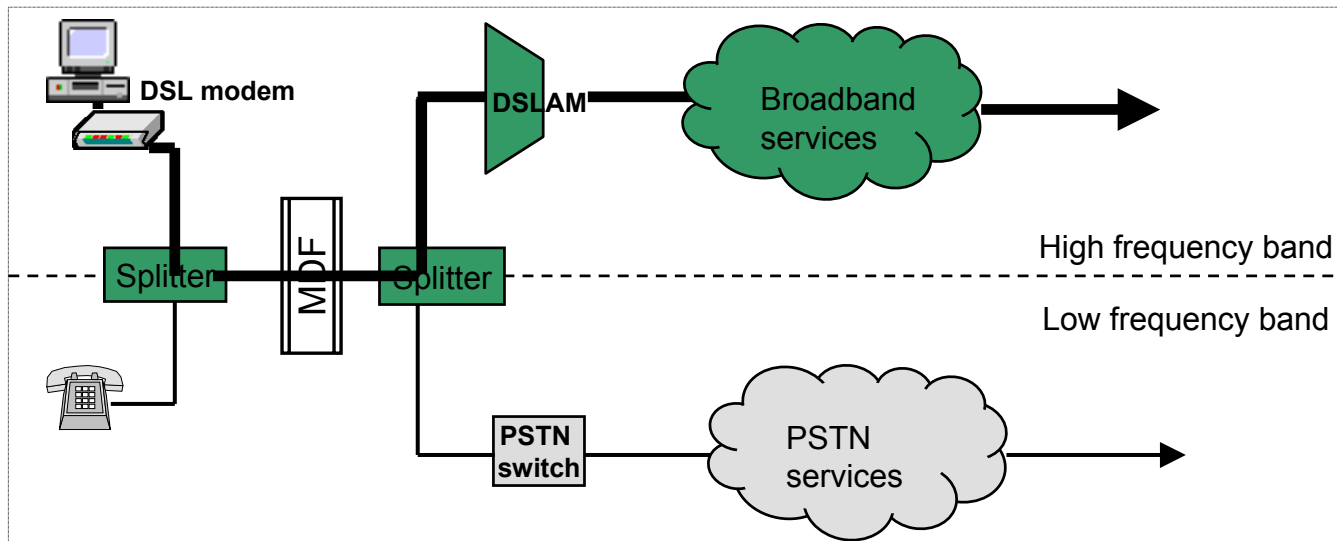

'Naked DSL' over shared access

Scenario 4 alternative operator provides both data and voice services over DSL in high frequency band

no services provided in the low frequency band – end user cancels PSTN subscription

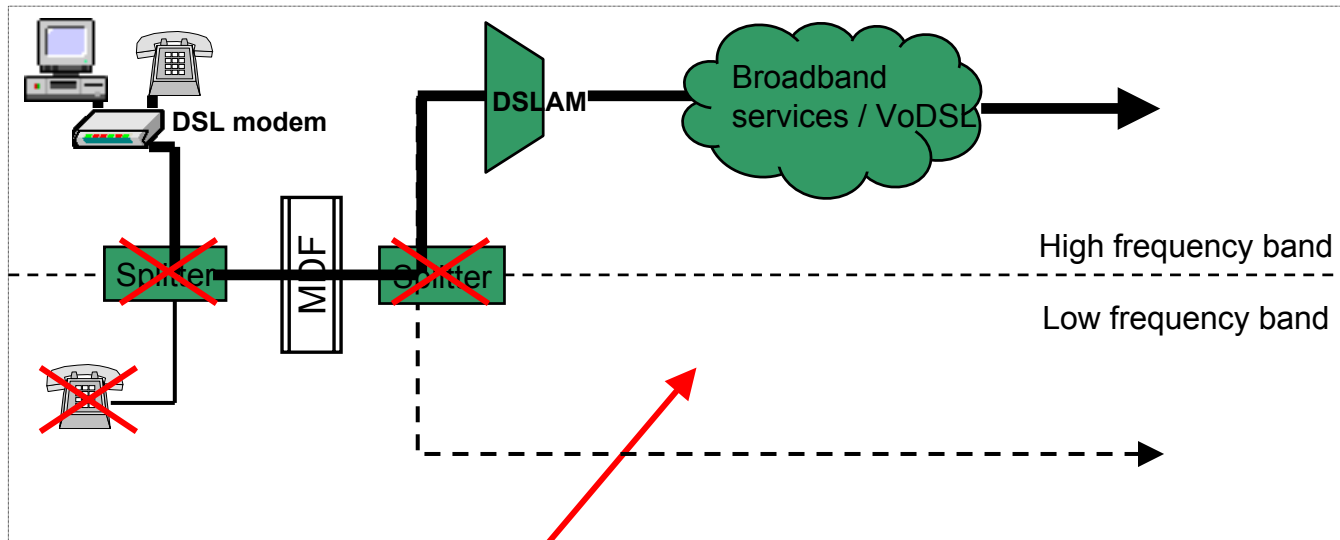

Who covers common costs?

'Naked DSL' over bitstream access

Scenario 5 alternative operator provides both data and voice services over DSL in high frequency band

no services provided in the low frequency band – end user cancels PSTN subscription

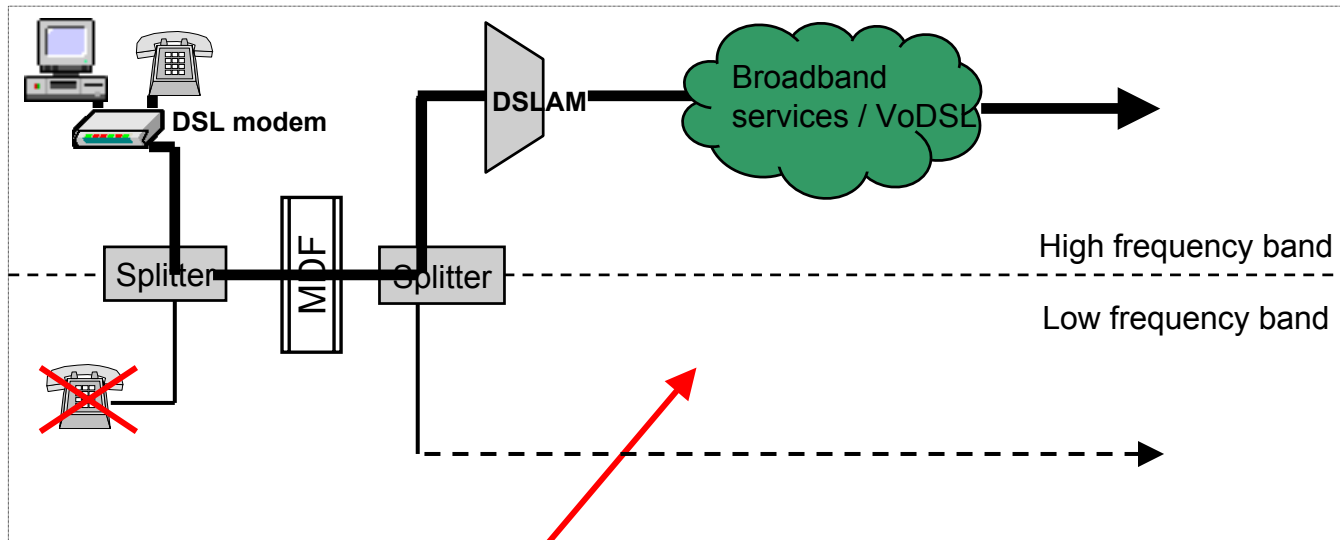

Who covers common costs?

‘Naked DSL’ – definition

- **Alternative operator provides DSL services in high frequency band of the copper loop based on
 - **shared access**
 - **bitstream access / DSL resale****
- **End-user has no PSTN subscription with local loop operator or WLR provider**
- **VoDSL instead of PSTN voice**
- **Enabler of VoB**
- **Common cost recovery?**

'Naked DSL' over shared access (I)

Country	NRA position		Available in practice?	Monthly fee
Belgium	Positive	BIPT draft decision on M 11 includes provision of shared access without voice services as part of access obligations to be imposed on Belgacom.	Yes	Full LLU
Denmark	Positive	NITA draft decision on M 11 includes 'administrative full access' as part of access obligations to be imposed on TDC – without mandatory migration to full access.	Yes	Full LLU
Italy	Positive	AGCOM draft decision on M 11 includes 'data unbundling service' as part of regulatory obligations for TI. Two pricing cases proposed: full LLU or standard shared access.	No	-
Norway	None	-	No	-
Spain	Negative	CMT decided that Telefónica's LLU Offer <u>should not</u> be modified to include 'naked ADSL' over shared access or BSA, because of the local loop cost recovery issue.	No	-
Sweden	Negative	PTS concluded that shared access can only be provided over loops where the low frequency band is used for PSTN/ISDN services. If the end user cancels the subscription in the low band – the operator has to migrate to full access product.	No	-

‘Naked DSL’ over shared access (II)

- **Two NRAs – Spain, Sweden – have ruled out naked DSL over shared access because of local loop cost recovery**
- **Three NRAs – Denmark, Italy, Belgium – proposed to regulate naked DSL over shared access as a wholesale product**
- **Only available in 2 European countries!**
- **Where available – priced same as full access**
- **European Commission on market 11, Italy:
‘naked’ shared access pricing to be consistent with full LLU**

'Naked DSL' over bitstream access (I)

Country	NRA position		Available in practice?
Austria	Positive	TKK draft decision on M 12 includes 'naked' DSL as part of access obligations for Telekom Austria.	No
Belgium	Positive	BIPT draft decision on M 12 includes 'naked' DSL as part of access obligations for Belgacom.	Yes
Denmark	Positive	NITA final decision on M 12 includes unbundled DSL (wholesale BSA without PSTN) as part of access obligations for TDC. Prices to be based on full LLU access + BSA specific charges, instead of current pricing as BSA with PSTN + 'bearer service fee' (=PSTN subscription)	Yes
Italy	Positive	AGCOM draft decision on M 12 requires TI to provide 'naked' BSA on non-active lines or lines without PSTN/ISDN subscription by end user. Prices to be based on standard BSA + (PSTN – 30%)	Yes
Norway	None	-	Yes
Spain	Negative	CMT decided that Telefónica's LLU Offer <u>should not</u> be modified to include 'naked ADSL' over shared access or BSA, because of the local loop cost recovery issue.	No
Sweden	Positive	PTS final decisions on M 1-2, 12 include an obligation for TeliaSonera to provide retail and wholesale broadband access, including bitstream access based on shared access, regardless of whether the end-user has a voice telephony subscription, and whether this subscription is provided by TeliaSonera or an alternative WLR operator.	Yes* *DSL resale without PSTN

‘Naked DSL’ over bitstream access (II)

- **Four NRAs – Denmark, Sweden, Italy, Belgium – have decided to regulate provision of naked DSL over BSA to open market for VoB**
- **Spanish NRA has ruled out naked DSL over BSA because of local loop cost recovery**
- **Available in 5 European countries**
- **Pricing approach varies**

'Naked DSL' over bitstream access (III)

Monthly surcharge for 'naked DSL' on the top of 'wholesale BSA with PSTN' set between full LLU access and retail PSTN monthly fees

Country	LLU		Naked DSL surcharge	Retail PSTN (ex VAT)
	Full access	Shared access		
Belgium	€ 11.62	€ 1.64	€ 9.98*	€ 14.17
Denmark	€ 9.00	€ 4.50	€ 13.00**	€ 13.00
Italy	€ 8.30	€ 2.80	€ 10.73 (residential)*** € 20.34 (corporate)	€ 11.66 (residential) € 18.30 (corporate)
Norway	€ 16.00	€ 9.00	€ 10.00	€ 16.00
Sweden	€ 11.43	€ 5.40	N/A	€ 11.00

* current charge, set as FA - SA

**current non-regulated charge, NITA proposed € 4.50 (= FA - SA)

***current non-regulated charge, AGCOM proposed 'retail PSTN - 30%' (€ 8 ...€ 13)